

Part Number: AE-DEE13001 Description: EE13 POWER TRANSFORMER

- EE13 Package in DIP
- Operating Temperature range: -40°C to +125°C
- Lead free wave soldering profile
- RoHS Compliant



Electrical Specifications @ 25°C

Inductance Lp @100KHz, 0.1V (1-2)	Leakage Inductance LK @100KHz, 0.1V (1-2)	Hi-Pot @60sec/3mA Pri to Sec
1.8~2.1mH	60uH max	3600Vac

Schematic

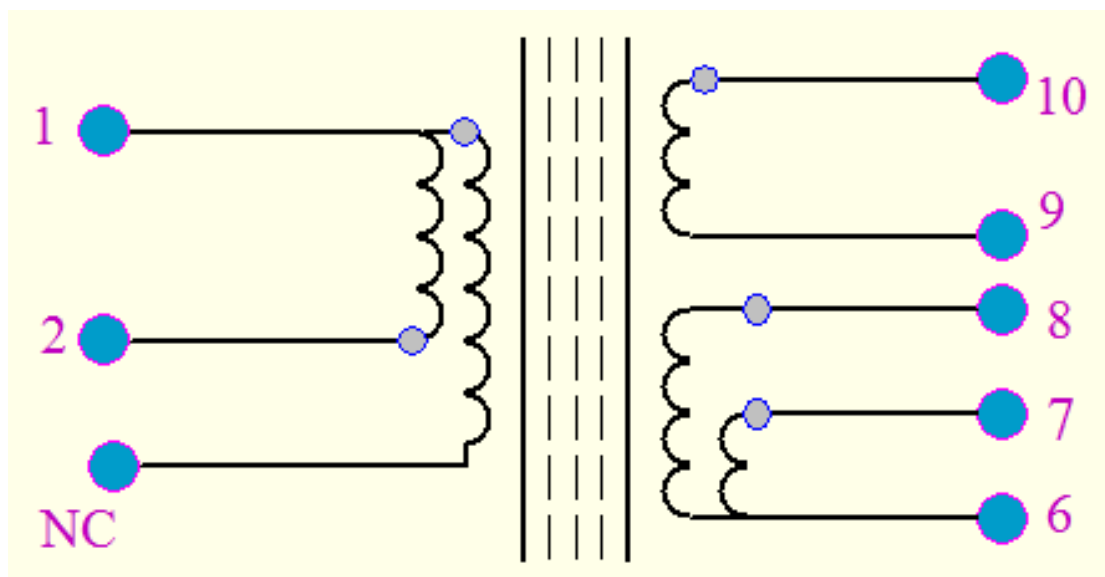

Mechanicals:

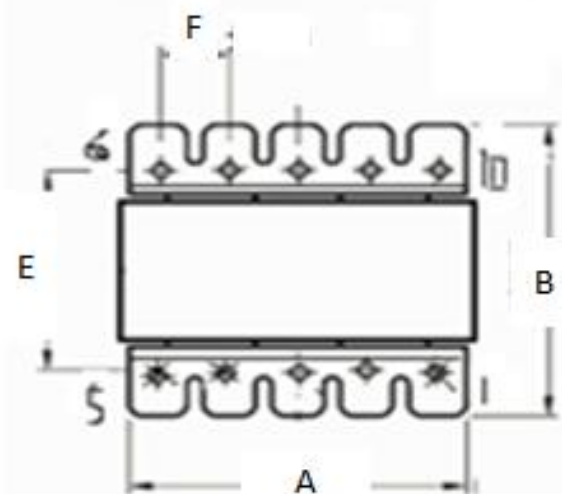
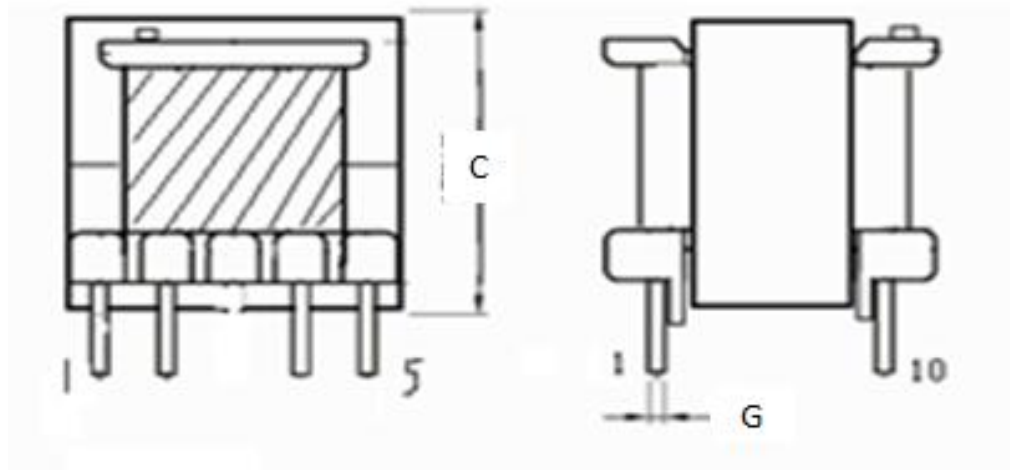

A	13.0 Max
B	11.0 Max
C	11.8 Max
D	3.0 ± 0.2
E	10.20 ± 0.2
F	6.0 ± 0.3
G	0.60 ± 0.10
Remark: 1. Unit : mm	

Rev	Date	Description	Who
A	Mar 5, 2016	New Release	JS Hill